



**POLARIS**  
The Way Out.

# TECHNICAL SERVICE BULLETIN

## Snowmobile

Bulletin Number: **S-03-07**  
Model Year(s): **2003**

Date: 01/22/2003

Safety Bulletin

Service Bulletin

Service Alert Fax

Production Update Kit

Distribution:  Owner / Principle  Service Manager  Sales Manager  Parts Manager  Technicians

*This Service Bulletin is located at [www.polarisdealers.com](http://www.polarisdealers.com)*

-Confidential and Proprietary-

### SUBJECT: 2003 800 RMK VERTICAL ESCAPE STEERING POST REPLACEMENT

Model(s) Affected	Model Number(s)	Serial Number Range
2003 800 RMK VERTICAL ESCAPE	S03NN8CS	ALL
2003 800 RMK VERTICAL ESCAPE ROLLING CHASSIS	S03NN8CSR	ALL

**PURPOSE:** The problem encountered with the Polaris Vertical Escape snowmobile involves the steering post. Specifically, the collar welded to the steering post can sometimes result in a weakening of the steering post due to an undercut condition at the weld toe, resulting in a thinner steering post wall section. If the condition is severe enough and occurs over a sufficient portion of the circumference of the steering post, the steering post can fail. This condition can result in the steering post separating and the handlebars and adjacent portion of the steering post becoming separated from the sled.

#### REPAIR PROCEDURE:

Remove steering post PN **1821251-067** and replace with replacement post kit PN **2202604**. Follow the instructions included in the kit.

#### CUSTOMER NOTIFICATION:

**Notify customers to stop riding their 2003 800 RMK Vertical Escape immediately!** A customer notification letter will be sent to all registered owners of affected units. A copy of the letter is included on page 3 of this bulletin. In addition to the notification letter sent by Polaris, dealers are required to notify owners of delivered units and make arrangements to perform this warranty repair.

#### PARTS INFORMATION

Polaris will be direct shipping replacement steering posts for each unit we show shipped to your dealership. You will be receiving partial shipments starting the week of January 20, 2003 and will continue to receive parts until you receive the total number of replacement kits for your allocation of 2003 800 RMK Vertical Escapes.

<b>Kit Part Number &amp; Description</b>	2202604, Kit-Vert Esc Replacement Post
<b>Quantity</b>	1
<b>Direct-Ship From Polaris?</b>	YES- Dealers will be direct shipped 100% of allocation and invoiced for replacement parts
<b>To Be Ordered By Dealer?</b>	NO-Parts will be automatically shipped.
<b>Availability</b>	Parts will ship from Polaris the starting the week of January 20, 2003.

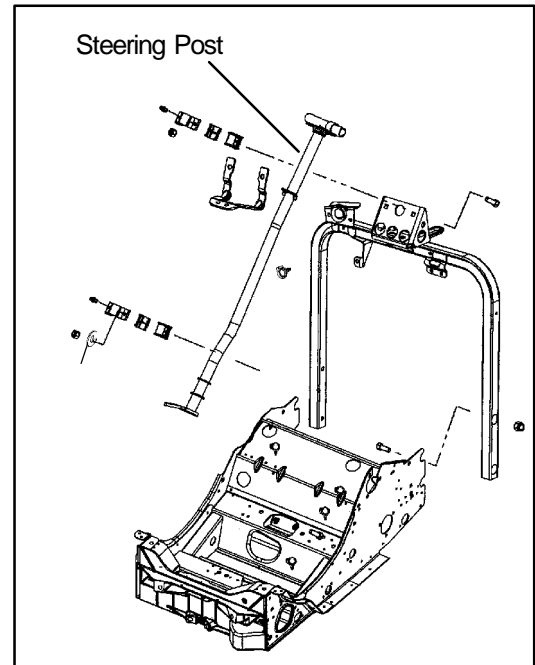

The information contained within this bulletin is confidential and protected by U.S. and international copyright laws, and is the property of Polaris Industries Inc. This service bulletin is provided for the sole use of authorized Polaris dealers and distributors. This service bulletin is not to be distributed, duplicated, or copied, digitally or otherwise, without the written consent of Polaris Industries Inc.

Printed in U.S.A. - © 2002 Polaris Industries Inc.

**PARTS IN DEALER INVENTORY:**

All steering posts (PN 1821251-067) in your inventory are suspect and must be removed from stock and returned. File a Parts Stock warranty claim (Claim Type PS) for steering posts in your inventory.

Also, please notify any customers who have purchased steering post PN 1821251-067 over the counter so they can return it for kit PN 2202604.

**WARRANTY CLAIM INFORMATION:**

When filing S-03-07, file claim type SB (Service Bulletin). Enter 2202604 in the primary failed part field, with a quantity of one (1) and return the section of the steering post shown in the photo at right along with the claim. A single group claim may be submitted listing the serial number for all machines with the same model number. DO NOT PUT MORE THAN ONE MODEL NUMBER ON A CLAIM.

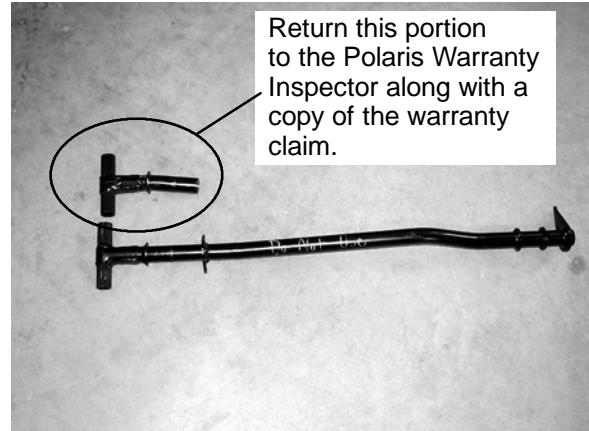

<b>Service Bulletin #</b>	S-03-07
<b>Claim Type</b>	SB
<b>Labor Allowance</b>	1:30
<b>Claim Part #</b>	2202604, 7170107

**NOTE:** The procedure to perform the replacement of the steering post was developed specifically for this bulletin and as such differs from the normal flat rate time. The time allowed was developed by doing 3 independent time studies using proper hand tools (no air tools).

To achieve the flat rate time of 1:30, follow the instructions included in the kit completely and thoroughly.

**SERVICE BULLETIN COMPLETION DECAL**

Fill out and attach a Service Bulletin Completion Decal, PN 7170107, to the air box as shown. If you require more decals, order them through your normal Polaris parts ordering channels.

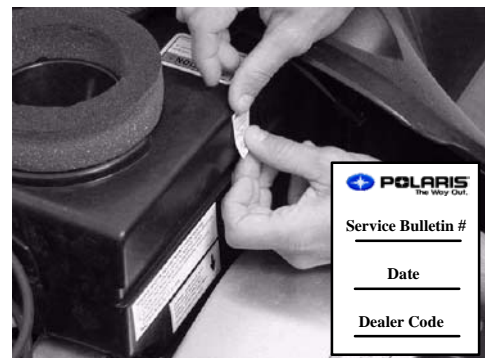

Sincerely,

*Karl Iverslie*

Karl Iverslie  
 Manager, Technical Service & Warranty

Snowmobile-S-03-07

# SAFETY RECALL NOTICE

## PLEASE READ IMMEDIATELY

January xx, 2003

Dear Polaris Snowmobile Owner:

In cooperation with the U.S. Consumer Product Safety Commission, Polaris Industries Inc. is conducting a voluntary safety recall of all 2003 800 RMK Vertical Escape snowmobiles. Our records indicate that you are the current owner of a potentially affected snowmobile.

This letter is to notify you that Polaris Industries Inc. has determined that some of the steering posts on the Vertical Escape model may have a defect in the weld in the area of the top washer guide. This defect can result in breakage and separation of the handlebar from the steering post. If this separation occurs a loss of steering control may occur. This could cause the driver to lose control of the snowmobile and crash, possibly resulting in injury or death.

**DO NOT OPERATE YOUR SNOWMOBILE UNTIL ALL REPAIRS HAVE BEEN COMPLETED!**

Please contact an authorized Polaris snowmobile dealer immediately to arrange to have the steering post replaced. Authorized Polaris dealers have been issued a Safety Alert Bulletin, S-03-07, that describes the required replacement and repair procedures. The dealer will replace the steering post. This work will be performed at no charge to you.

This notice was sent to you according to the most current information we have available. If you no longer own this snowmobile, please provide us with the name and address of the current owner, or notify us that you do not have this information.

If you have any questions about this notice, or need assistance with contacting a Polaris Dealer, please call 1-800-POLARIS or visit the Polaris web site at [www.polarisindustries.com](http://www.polarisindustries.com).

We apologize for any inconvenience this may have caused you.

Sincerely,  
John H. Zimmerman  
Polaris Sales Inc.  
Customer Service Phone 763-417-8650